

φ 68 Medium Duty Standard Shaft Type

Diameter φ 68mm shaft type INCREMENTAL Rotary encoder

■ Features

- Diameter φ 68mm, Shaft φ 15mm
- High speed response frequency : 180kHz
- Connector type
- Suitable for tooling machinery
- IP64 (Partial water proof, Drip proof)
- Strong shaft type (Allowable weight 10kgf)



⚠ Please read "Caution for your safety" in operation manual before using.

■ Ordering information

E68S	15	1024	6	L	5
Series	Shaft diameter	Pulse/1 Revolution	Output phase	Output	Power supply
Diameter φ 68mm, shaft type	φ 15mm	1024 P/R	6 : A, \bar{A} , B, \bar{B} , Z, \bar{Z}	L : Line driver output	5VDC ± 5%

■ Specifications

Item		Diameter φ 68mm shaft type Incremental Rotary encoder
Resolution(P/R)		1024 P/R (Not indicated type is available to customize)
Electrical specification	Output phase	A, \bar{A} , B, \bar{B} , Z, \bar{Z} phase
	Phase difference of output	Output between A and B phase : $\frac{T}{4} \pm \frac{T}{8}$ (T=1cycle of A phase)
	Output Duty rate	• A, B phase Duty rate : $\frac{T}{2} \pm \frac{T}{8}$ • Z phase Duty rate : $T \pm \frac{T}{4}$
	Control output	• Low \Rightarrow Load current : Max. 20mA, Residual voltage : Max. 0.5VDC • High \Rightarrow Load current : Max. -20mA, Output voltage : Min. (Power voltage-2.5)VDC
	Responsetime(Rese/Fall)	Max. 0.5 μ s (Cable:1m, I sink = 20mA)
	Power supply	5VDC ± 5% (Ripple P-P : Max. 5%)
	Max. Response frequency	180kHz
	Current consumption	Max. 50mA
	Insulation resistance	Min. 100M Ω (at 500VDC)
	Dielectric strength	750VAC 50/60Hz for 1 minute (Between all terminals and case)
	Connection	Connector connection (MS3102A20-29P)
Mechanical specification	Starting torque	1.5kgf · cm (Max. 0.15N · m)
	Shaft loading	Radial : 20kgf, Thrust : 10kgf
	Deviation of shaft position	Radial : Max. 0.1mm, Thrust : Max. 0.2mm
	Max. allowable revolution	(★Note1) 6,500rpm
Vibration	1.5mm amplitude at frequency of 10 ~ 55Hz in each of X, Y, Z directions for 2 hours	
Shock	Max. 30G	
Ambient temperature	0 ~ 70°C (at non-freezing status), Storage:-25 ~ 85°C	
Ambient humidity	35~85%RH, Storage: 35~90%RH	
Protection	IP64 (IEC specification)	
Weight	Approx. 550g	

※ **(★Note1)** Max. allowable revolution \geq Max. response revolution **[Max. response revolution (rpm) = $\frac{\text{Max. response frequency}}{\text{Resolution}} \times 60 \text{ sec}$]**

Please select the resolution to make lower max. revolution than max. allowable revolution.

(A) Counter

(B) Timer

(C) Temp. controller

(D) Power controller

(E) Panel meter

(F) Tacho/Speed/Pulse meter

(G) Display unit

(H) Sensor controller

(I) Proximity sensor

(J) Photo electric sensor

(K) Pressure sensor

(L) Rotary encoder

(M) 5-Phase stepping motor & Driver & Controller

E68S15

Control output diagram

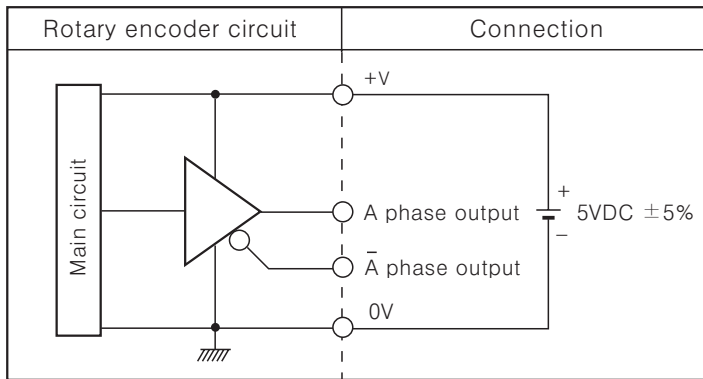

※All output circuit is the same A, A-bar, B, B-bar, Z, Z-bar phase.

Output waveform

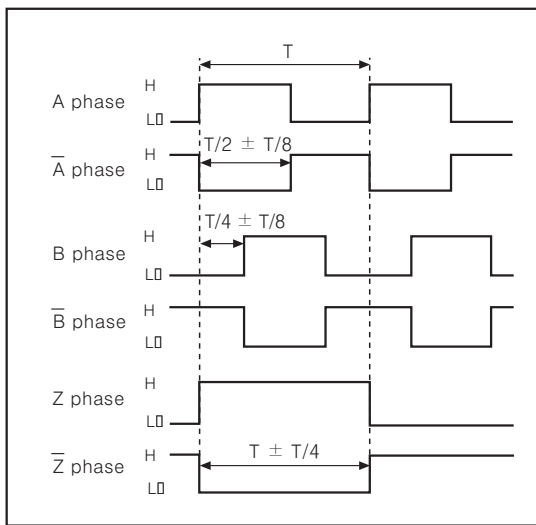

※Rotating direction: CW

Connections

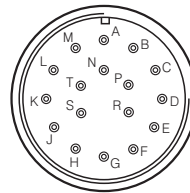

Pin No.	Cable color	Pin No.	Cable color
A	A phase	K	0V
B	Z phase	L	NC
C	B phase	M	0V
D	NC	N	A-bar phase
E	5VDC	P	Z-bar phase
F	NC	R	B-bar phase
G	NC	S	NC
H	5VDC	T	Shield(F.G)
J	NC	—	—

※N.C : Not Connected.

※E and H terminals, K and M terminals are connected internally.

Dimensions

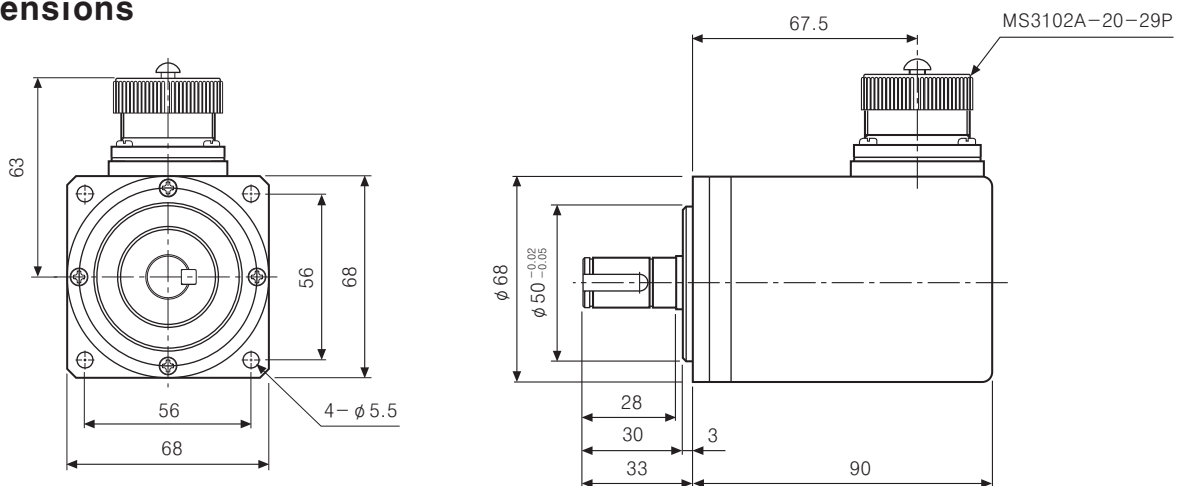

●Shaft dimension

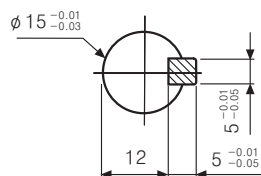

Unit:mm